

Rockfall protection system

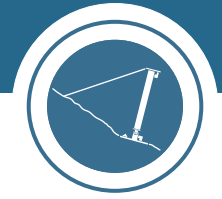

TS-750-ZD - Data Sheet



Area of Application:

TRUMER rockfall catchment fences were developed to protect infrastructure, utilities, buildings and lives from falling debris. Typical catchment fences are installed in run-out or deposition zones, close to the elements at risk that they protect. The TS-750-ZD is used for projects of high risk (Consequence Class in EN 1990:2003 [1]) as per ONR 24810 [2].

Material:

TRUMER uses steel components and steel wire ropes made from high quality materials, following a stringent quality assurance program. The structure was tested as per WLV guidelines [3]. TRUMER Schutzbauten GmbH is ISO 9001:2008 certified.

Installation:

The TS-750-ZD has been designed with as few components as possible to simplify installation and reduce maintenance. In addition, the systems can be installed by hand, with heavy machinery or with the use of a helicopter. Foundation design and construction is dependant on site conditions and are the responsibility of the project engineer.

Advantages:

This system has been tested with no failures of primary components even though certification allows such failures. As such, the TS-750-ZD rockfall catchment fence carries the highest safety ratings.

Classification

Model	TS-750-ZD
Style	Hinged System
Energy Class	2
Maximum Energy Level Certified/Tested kJ (ft-tons)	750 / 774 (277) / (285)
Service Energy Level kJ (ft-tons)	N/A
Approved Heights m (ft)	4.0 - 6.0 (13.1 - 19.7)
Verification	Full Scale Tested
Certification	Acc. WLV Guideline

Test Report Summary

Test Height m (ft)	4.0 (13.1)
Maximum Elongation m (ft)	5.76 (18.90)
Residual Height Class	A (≥50%)
Component Failure	None
Primary Net Opening	None
Secondary Mesh	None

Test Report

Report Number	0202
Issuing Body	Montanuniversität Leoben
Date of Issue	August 23, 2002

References:

1. CEN. EN 1990:2003, Eurocode – Basis of structural design. 2005.
2. Austrian Standards Institute. ONR 24810, Technical protection against rockfall - Terms and definitions, effects of actions, design, monitoring and maintenance, 2013.
3. Austrian Service for Torrent and Avalanche Control WLV. WLV-Richtlinie für den Eignungsnachweis von Steinschlag-schutznetze, May 2005.

Primary Net

Model	Omega-Net 7.5/135
Type	Steel Wire Cable
Rope Diameter <i>mm (in.)</i>	7.5 (0.295)
Rope Construction	1 x 7 Spiral
Single Wire Diameter <i>mm (in.)</i>	2.5 (0.098)
Corrosion Protection	Zn or ZnAl (Class A)
Mesh Size <i>mm (in.)</i>	~ 135 x 135 (5.3 x 5.3)
Unit Weight <i>kg/m² (lb/ft²)</i>	~ 5.6 (1.15)
Mesh Tensile Strength calculated <i>kN/m (lb/ft)</i>	386 (26449)
Connection to Main Ropes	Threaded
Connection to Adjacent Panel	3/8" Shackle

Ropes

Bearing	Quantity per fence segment	2
	Rope Diameter <i>mm (in.)</i>	24 (0.945)
	Corrosion Protection	Zn or ZnAl (Class A or B)
	Brake Elements per rope	2
Middle	Brake Element Model	AVT phx 60/25-2.5
	Quantity per fence segment	N/A
	Rope Diameter <i>mm (in.)</i>	N/A
	Corrosion Protection	N/A
Retaining	Brake Elements per rope	N/A
	Brake Element Model	N/A
	Quantity per post	2
	Rope Diameter <i>mm (in.)</i>	18 (0.709)
	Corrosion Protection	Zn or ZnAl (Class A or B)
	Brake Elements per rope	N/A
	Brake Element Model	N/A

Support Structure

Post Type	HEA 140
Integrated Ladder	Rungs every 0.5 m
Rope Guides	Integrated
Post Weight 4 meter post height <i>kg (lbs)</i>	127 (280)
Base Plate Connection	Tongue and Pin
Base Plate Footprint <i>mm (in.)</i>	790 x 250 (31.1 x 9.8)
Base Plate Weight <i>kg (lbs)</i>	37 (82)
Anchors per base plate	2

Base Plate/Foundation

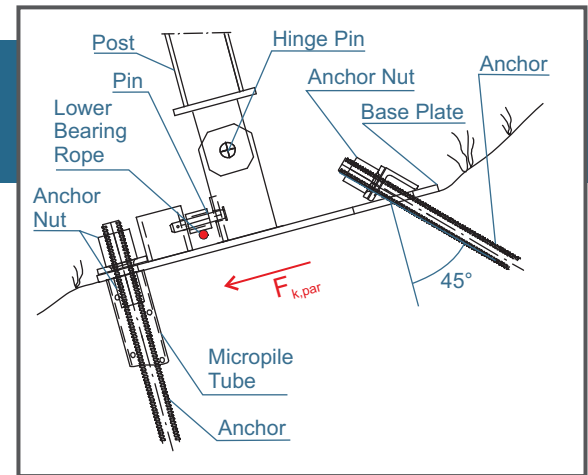

Lateral Anchorage

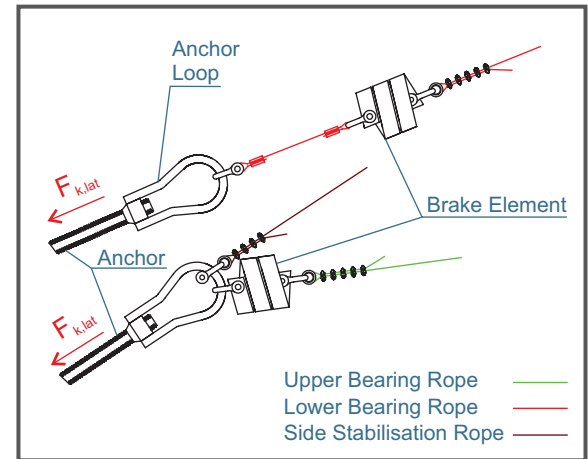

Retaining Rope Anchorage

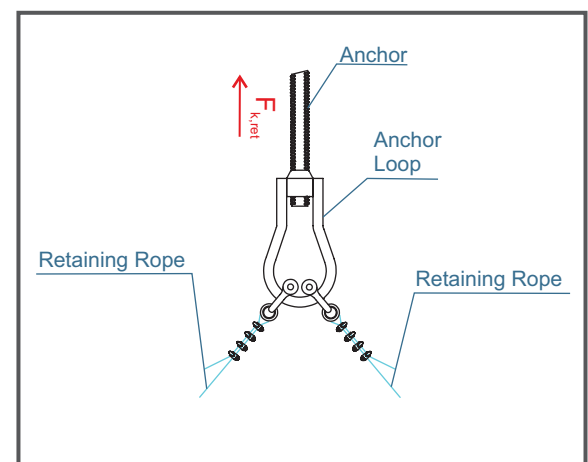

Anchor Forces *kN (kips)*

Base Plate ($F_{k,par}$)	232 (52.2)
Max. Lateral Anchor ($F_{k,lat}$)	246 (55.3)
Retaining Rope Anchor ($F_{k,ret}$)	277 (63.3)

Typical Recommended Anchors Based on Steel Grade*

(per 50 m, 10 m post spacing)

	Quantity	500/550 (MPa) (e.g. GEWI)	670/800 (MPa) (e.g. GEWI Plus)	470 min (MPa) (e.g. IBO)
Base Plate Anchor	12	32	28	site dependent
Lateral Anchor	4	40	28	R38-550
Retaining Rope Anchor	7	40	30	R51-660

* Actual anchorage to be determined by a qualified engineer in accordance with local regulations. Herein, the factors of safety were applied according to the ONR 24810 guidelines. If multiple ropes are led to one anchor, it is recommended that characteristic force values be added in a scalar manner according to ONR 24810.

Typical Cross Section

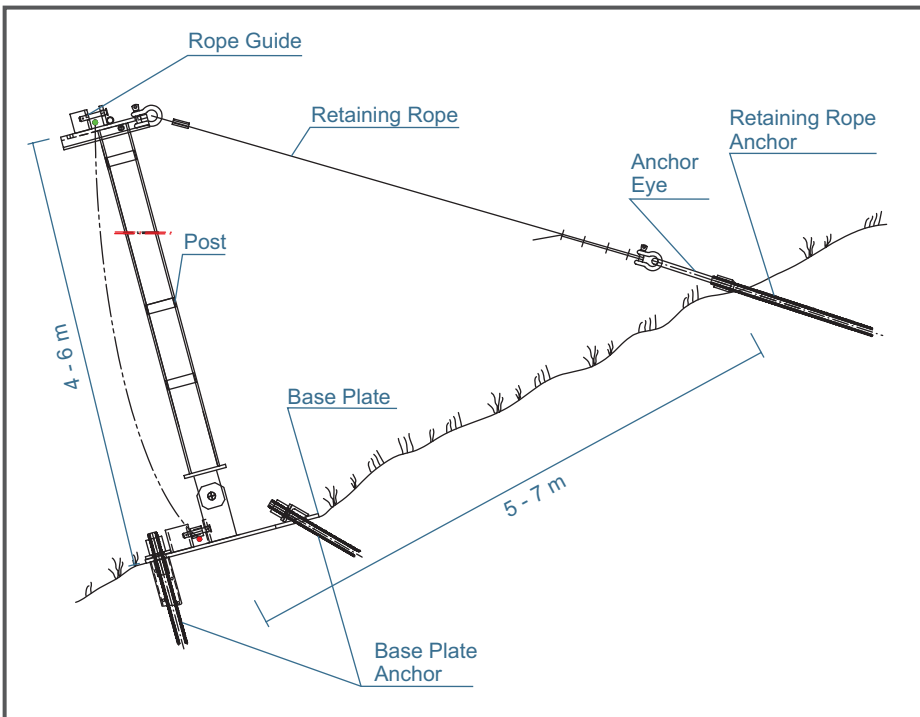

General Layout and Anchorage:

The suggested layout for the rockfall catchment fence follows the constructive rules of the ONR 24810. In general, post spacing is kept between 8 - 12 m. Posts should be positioned to create the greatest capture shadow with regards to vertical as well as lateral spread of falling debris, with the fence roughly perpendicular to the fall line. Avoid the placement of posts in areas that increase the chance of a direct post impact.

Anchor layout should follow the geometry provided in the installation manual with the anchor oriented as close as possible to the direction of the anticipated rope forces. It is acknowledged that due to site characteristics deviations from the ideal are unavoidable. In this case, the project engineer should use their best judgement to find a suitable location and orientation.

Typical Layout

